

**MAGMA**

EWE Studio collaborated with Nouvel Studio to produce the Magma light series. The process began with designing molds varying in size and scale, hand carved in volcanic stone where the glass is blown. The artisanal glass blowing process, gives the unique characteristics to each one of the Magma 'bubbles'.

The structure that holds the Magma is made out of cold bluing steel. The interior is a hand hammered brass surface contained within the glass bubbles.

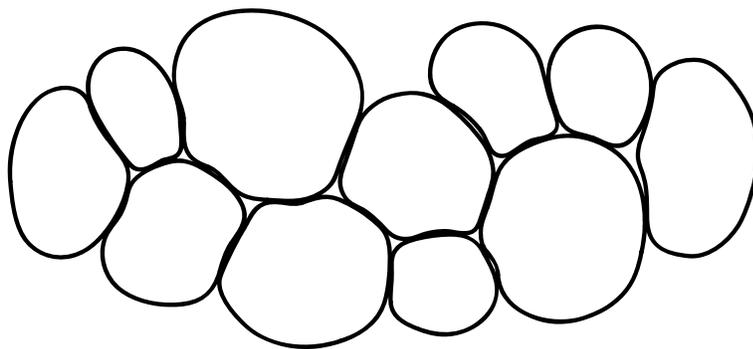

160 cm  
62 in

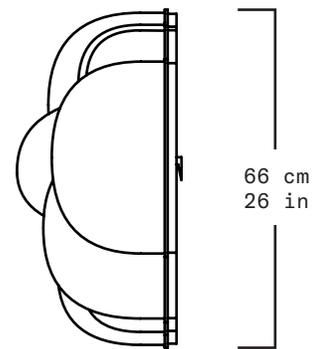

33 cm  
13 in

66 cm  
26 in

Collection	Alquimia
Product	Magma Large Black
Measurements	L160 x W33 x H66 cm L62 x W13 x H26 in
Weight (Kg)	160
Materials	Black Blown Glass, Steel, LED Lights
Finishes	Cold Bluing
Edition	Limited Edition of 10 + 1 AP
Lead Time	18 - 20 weeks
Illumination	Dimmable LED Strip Light, 2 400K, 24V DC, 16w/m, 1125 lumens/m