



info@ewe-studio.com
www.ewe-studio.com

P I T A O

For EWE Studio's first armchair piece, the studio continues redefining Mexican vast legacy of cultures, precisely taking a closer look at the Zapotec civilization, who were the pre-Columbian civilization that flourished in the Valley of Oaxaca in Mexico.

Pitao Armchair got its inspiration from the Zapotec God of Rain figure "Pitao Cocijo" and the glyph C, which was used in the representation of the god, as figures in their headdresses or as vases in their hands. Glyph C symbolic shape was the direct inspiration behind the armchair's backrest form.

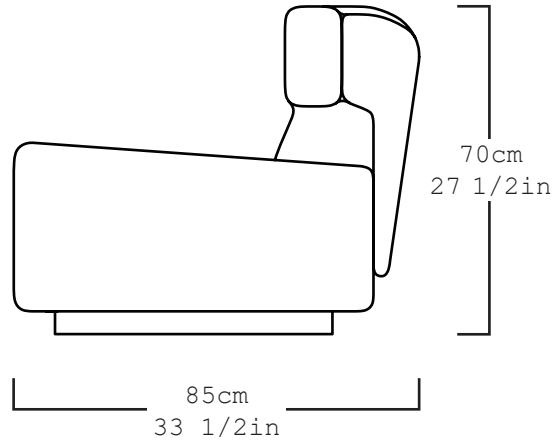
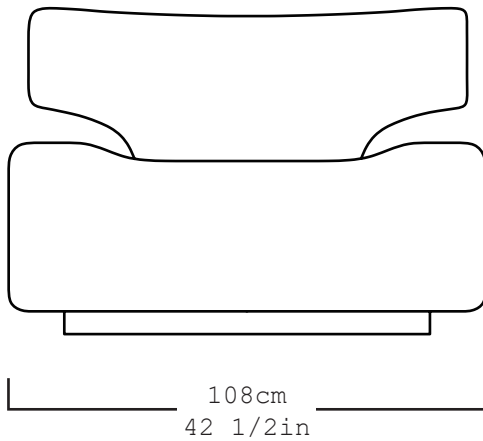

Collection	Recover / Uncover
Product	Pitao Armchair
Dimensions	L108 x W85 x H70 cm L42 1/2 x W33 1/2 x H27 1/2 in
Materials	Black Leather and Brass
Weight (Kg)	35
Finishes	Matte black leather and semi-matte satin brass
Edition	Open Edition
Lead Time	8 - 10 weeks